

SECTION THRO 'A'-'A'

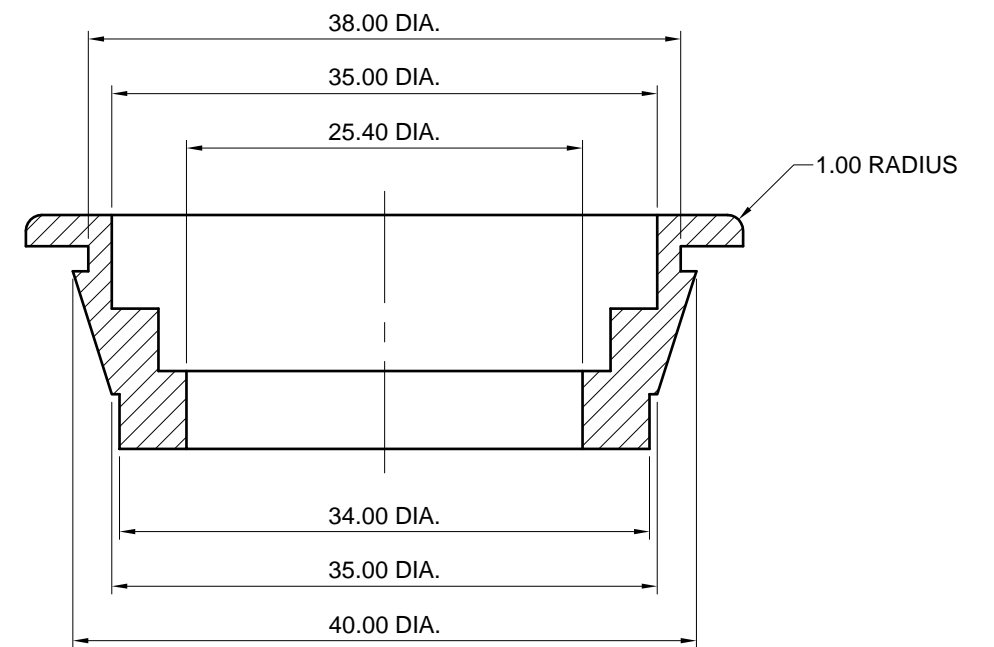

SECTION THRO 'B'-'B'

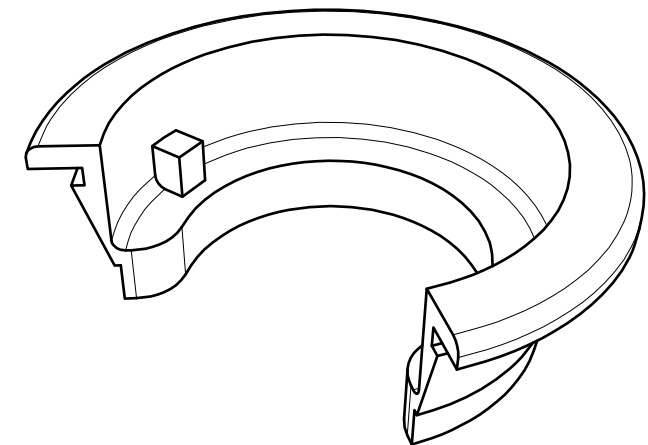

				Drawn	MB	...	SURFACE TEXTURE IN MICROMETERS REMOVE SHARP EDGES TOLERANCES EXCEPT WHERE OTHERWISE STATED DIMENSIONAL ± 0.5 ANGULAR $\pm 0.5^\circ$	 Drawing Produced By Redgate Engineering Limited B.B.I.C., Snydale Road, Cudworth, Barnsley, South Yorkshire S72 8RP Tel.: 01226 714106 Fax.: 01226 700722 Email: office@redgateengineering.co.uk	Title		SPLIT COLLAR	
				Checked					Drg. No. TS3-00-783			
				Approved					Rev.			
No.	Revision	Chg'd	App'd	Date	Scale : 2 : 1 @ A3			ALL DIMENSIONS IN MILLIMETRES	DO NOT SCALE		IF IN DOUBT ASK!	
This drawing is confidential and is not to be disclosed to any third party without written permission of Redgate Engineering Limited								PROJECTION				