

TECHNICAL SHEET :	TS 092
DATE :	...
DRAWN :	REL
APPROVED :	MB
TITLE :	TYPICAL STAIRCASE DETAIL

## TECHNICAL INSTRUCTION SHEET

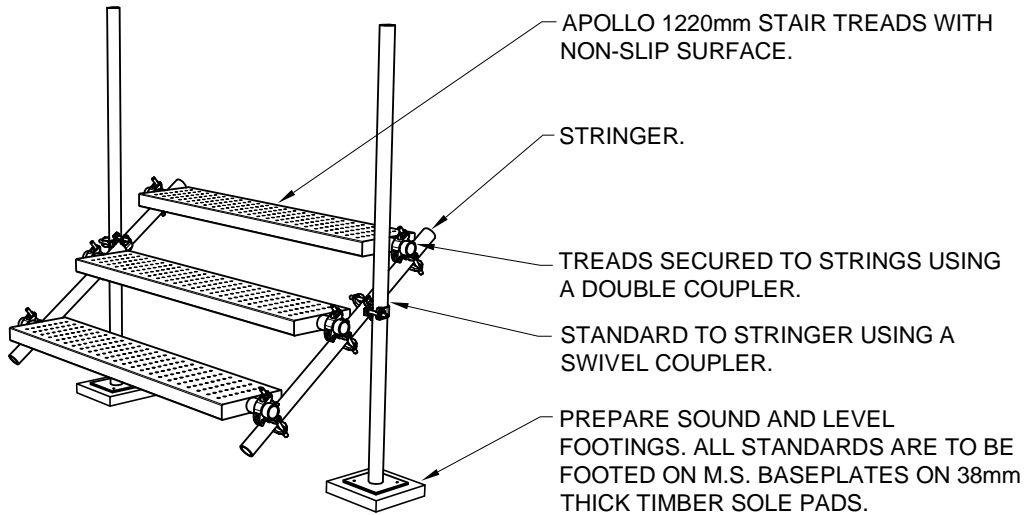

## PART PERSPECTIVE VIEW ON STAIRCASE

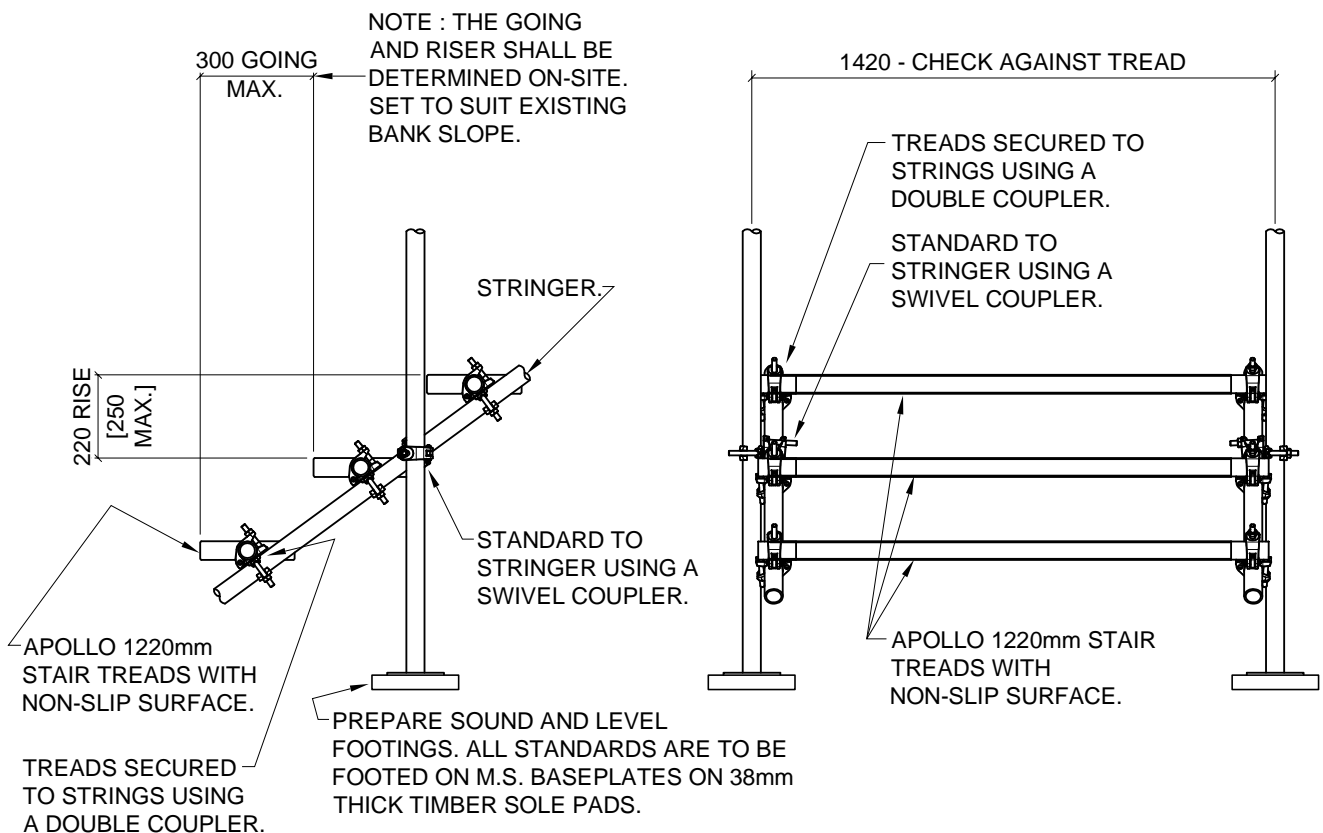

ELEVATION

SECTION THRO' STAIRCASE