

Features and Options

Welded feet

for S35, S70, D35 & D70

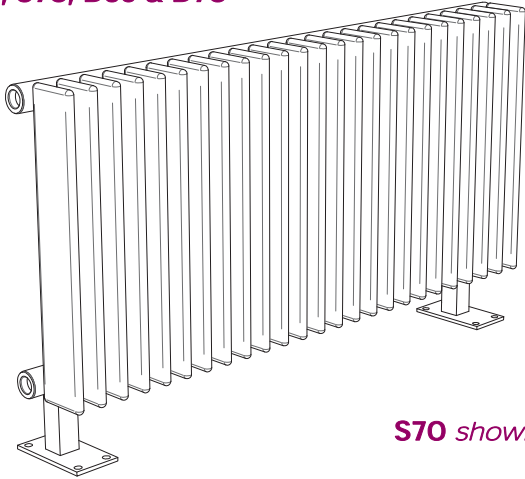

S70 shown

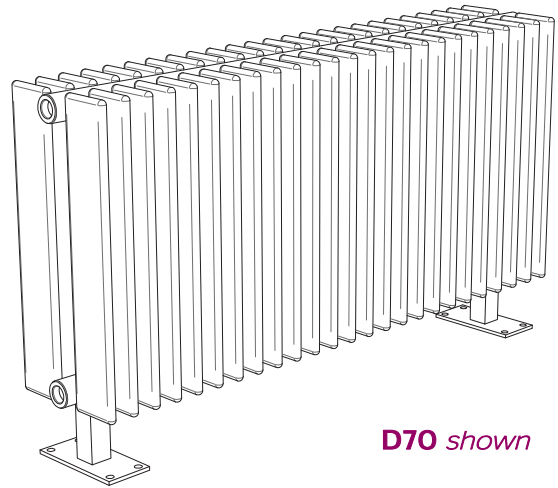

D70 shown

Extended element feet

for S35, S70, D35 & D70

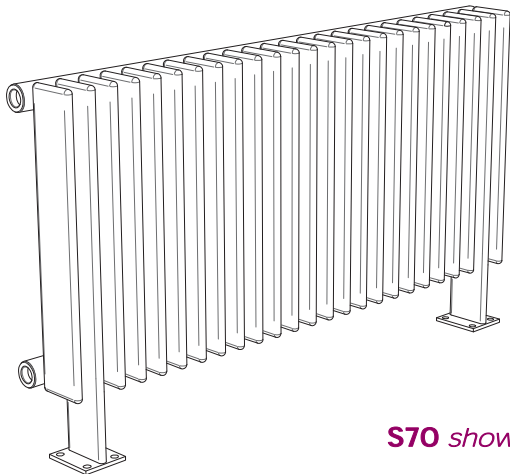

S70 shown

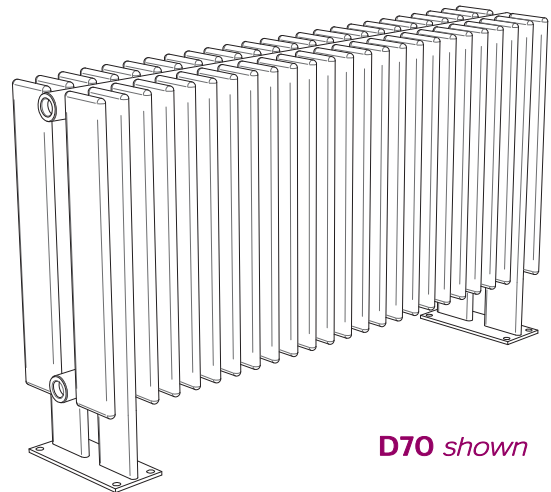

D70 shown

Outsize Columns / Split Columns

When the length and height each exceed 900mm, column radiators are delivered in two pieces, and are connected on site by means of specially designed connection pieces, supplied with the radiator (see Sample Installation Sheets page 51/52). The pitch remains constant for the entire length of the assembled unit. Please contact the sales office.

Floor - Mounting

Floor-mounting brackets (AKA Feet) are available for all Quinn Merriott column radiators, for a premium. The options for floor-mounting are:

- 1.) Welded Feet (See page 50)
- 2.) Extended Element Feet (See page 50)
- 3.) Retrofit Feet (See page 50)

Options 1 & 2 can only be supplied as part of the radiator, this detail must be specified at the time of order. For floor-mounting units above 500mm high (radiator and floor-mounting bracket), it is strongly recommended to also add top supports to ensure stability. Please contact the sales office if additional information is required.

Connection variations

Quinn Merriott column radiators are supplied with four 1/2" (15mm) connections as standard. Non-standard connections are available on all columns. As baffles are required in the header tubes, to allow for water movement throughout the radiators, the flow and return direction must be identified on all column radiators at time of order.